

AQA, Edexcel, OCR

A Level

A Level Physics

ELECTRICAL CIRCUITS:

Complete Circuits 2 (Answers)

Name:

M

M

E

Mathsmadeeasy.co.uk

Total Marks: /30

1. This question is about the power supplied to a circuit.

Total for Question 1: 13

(a) Explain the terms *terminal P.D.*, *lost volts* and *internal resistance*.

[3]

Solution: Sources of emf have a small but non-zero resistance. This is termed *internal resistance*. Thus, sources can be analysed as an emf in series with a resistor. The potential difference across this resistor is termed the *lost volts*, as it cannot contribute to useful work done by the circuit components. The terminal P.D. will then be the useful voltage of the power supply i.e. the emf minus the lost volts. This is all encapsulated by: $\epsilon = V_{terminal} + Ir_{internal}$

(b) Outline an experiment that could be performed to investigate the internal resistance of a power supply. Include details of the apparatus used, the measurements taken and any data analysis performed.

[4]

Solution: Apparatus: power supply in series with variable resistor and ammeter; voltmeter across the power supply.
A change in R will induce a change in the current. Measurements: V and I for each incremental change in R.
The equation $\epsilon = V_{terminal} + Ir_{internal}$ takes form of straight line: intercept ϵ and gradient $-r$.

Jeremy is provided with two cells, each with an emf, ϵ , of 6 V and an internal resistance, r , of 0.4Ω . Any power supply he constructs will be connected to a 10Ω resistor, through which he wishes to maximise the current.

- (c) Jeremy does not know how best to combine his cells. Calculate ϵ_{total} and I for each of the following arrangements below and determine his best course of action. [4]
- A single cell.
 - Two cells connected in parallel.
 - Two cells connected in series.

Solution: For one cell: $\epsilon = 6 \text{ V}, I = 0.58 \text{ A}$

For parallel: $\epsilon = 6 \text{ V}, I = 1.16 \text{ A}$

For series: $\epsilon = 12 \text{ V}, I = 0.58 \text{ A}$

He should combine his cells in parallel: the emf will be the same as for the single cell and the current will be greatest.

- (d) Give an example of when low and when high internal resistances might be desirable. [2]

Solution: Affects the maximum current.

High: any devices likely to be misused, since the current will be limited e.g. classroom equipment.

Low: for high currents e.g. fast chargers, starter motors' batteries.

2. Many cordless hair-dryers have more than one setting. One way in which this can be achieved is by using a potential divider circuit: when the user changes the setting, the resistance of a variable resistor is changed and, as a consequence, the power output to the dryer changes. A simple circuit that could be used for this is shown in Figure 1.

Total for Question 2: 17

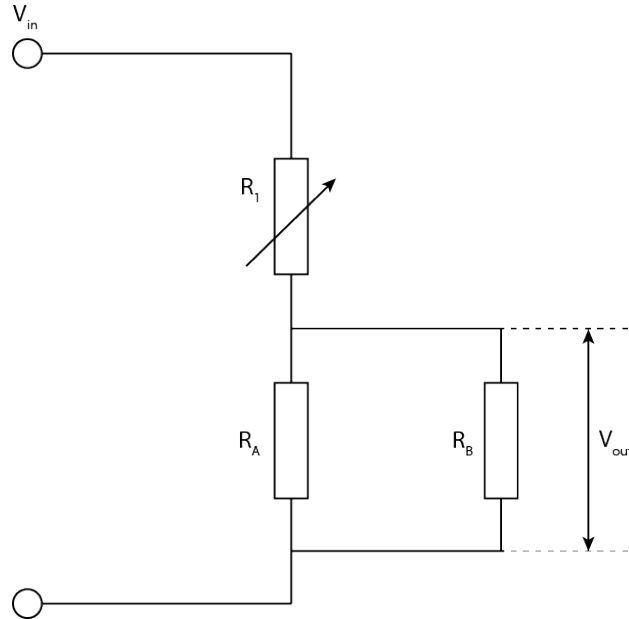

Figure 1: A circuit containing three components and a power supply. R_B is the resistance of the hair-drying mechanism.

- (a) Using Ohm's Law, it is possible to show that the potential differences and resistances are linked by the equation [2]

$$\frac{V_1}{V_{out}} = \frac{R_1}{R_2}$$

where R_2 is the combined resistance of resistors A and B. Use this knowledge to show that

$$V_{out} = \frac{V_{in}R_2}{R_1 + R_2}$$

Solution: $\rightarrow V_1 = \frac{R_1 V_{out}}{R_2}$

But, $V_{in} = V_1 + V_{out} \rightarrow V_{in} = V_{out} + \frac{V_{out}R_1}{R_2} \rightarrow V_{out} = \frac{V_{in}R_2}{R_1 + R_2}$

- (b) Given that $R_A = 5 \Omega$ and $R_B = 100 \Omega$, calculate R_2 . [1]

Solution: 4.76Ω

- (c) The low, medium and high settings on the hair-dryer correspond to values for V_{out} of 6, 8 and 10 V, respectively. For each case, calculate R_1 . [3]

Solution: Low: 4.76Ω
Med: 2.38Ω
High: 0.95Ω

Elaine is using the hair-dryer on its 'high' setting. To fully dry her hair, each square metre of hair surface requires 3 kJ. Her hair has a surface area of 0.1 m².

- (d) Calculate the power dissipated across R_B and hence the minimum amount of time required to dry Elaine's hair. Why is this a lower bound on the amount of time taken? [4]

Solution: 1 W

5 minutes

Assumes that no power is dissipated as non-useful forms e.g. frictional heating of the fan mechanism.

- (e) How would your answer change if R_B were lowered? Why is this? [2]

Solution: If R_B is lowered then R_2 reduces because of the parallel nature of the two fixed resistors. Consequently, for a given R_1 , V_{out} will reduce. This would reduce the power of the hair-dryer and increase the time taken.

So far you have explored how potential dividers can be used to modulate the power output, given a fixed power input. They can also be exploited in sensing circuits.

- (f) Design a potential divider circuit which decreases V_{out} as temperature rises.

[2]

Solution: An NTC thermistor be connected in series to a fixed resistor. V_{out} is the potential difference across the fixed resistor.

- (g) A machine used by the highways agency to re-paint faded white lines on the road network relies on an LDR sensing circuit to stay on the right course. The circuit comprises an LDR connected in series to a $500\ \Omega$ resistor and a 30 V power supply. The paint feeder will only dispense paint when V_{out} exceeds 28 V. Calculate the maximum resistance of the LDR when lines are being painted.

[3]

Solution: $36\ \Omega$