

OCR

A Level

A Level Physics

ELECTRICAL CIRCUITS:

Complete Circuits 1

Name:

M M E

Mathsmadeeasy.co.uk

Total Marks: /30

1.

Total for Question 1: 8

- (a) Define electrical work, W , in terms of potential difference, V , and charge, Q . Using this relationship, show that $P = I^2R$ [2]

- (b) The P.D. across a 5.0Ω resistor is measured as 6.0 V . What power is it dissipating? [2]

- (c) An LED is connected in series with an ammeter and a power supply. A voltmeter is connected across the LED. They read 2.2 A and 4.6 V . If it is left on for 1 hour and 15 minutes, how much work is done by the LED? [2]

- (d) Sketch how the electrical work done by the resistor at a given point in time would vary with the resistance of the resistor. Assume the P.D. across the resistor is constant. [2]

2. This question exploits Kirchoff's laws to determine the resistances of several components in Figure 1.

Total for Question 2: 10

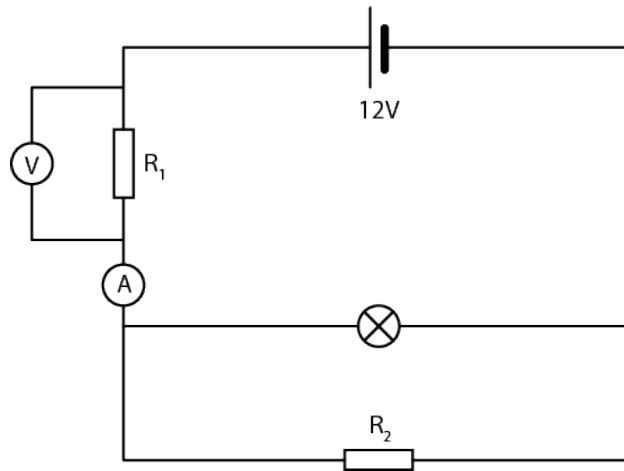

Figure 1: A circuit containing two resistors, a voltmeter, an ammeter, a cell and a bulb.

Tom notes that the the bulb has an effective resistance of 5.0Ω , that the voltmeter reads 2.0 V and that the ammeter reads 3.5 A .

(a) State Kirchoff's First Circuit Law. What implications does it have for the charge entering and leaving a circuit junction? [2]

(b) State Kirchoff's Second Circuit Law. [1]

(c) Calculate R_1 . [1]

(d) Calculate R_2 . [3]

(e) Calculate the power dissipated by the bulb. [1]

(f) The bulb dissipates 75% of its power as heat and converts the rest to light. What is the efficiency of this circuit as a means of lighting? [2]

3. Based on the conservation of charge and of energy, it is possible to derive several laws that dictate how the total effective resistance in a circuit varies when a combination of resistors are used in series and/or parallel.

Total for Question 3: 8

- (a) Use Kirchoff's and Ohm's laws to derive an expression for the total effective resistance of two resistors, R_{1-2} , in series. [2]

- (b) Using a similar technique, show that for two resistors in parallel, $\frac{1}{R} = \frac{1}{R_1} + \frac{1}{R_2}$. [3]

- (c) Two resistors (1.0Ω and 2.0Ω) connected in parallel are linked in series to a 3.0Ω resistor. All of this is in parallel with a fourth resistor. If the total effective resistance is 1.0Ω , what is the resistance of the fourth resistor? [3]

4. Draw the symbols for the following circuit components:

Total for Question 4: 4

(a) An LED.

[1]

(b) A variable resistor.

[1]

(c) A thermistor.

[1]

(d) An LDR.

[1]